

## Weebit Nano Ltd – Update Report

09.11.2022



Stock Exchange  
**ASX**



Symbol  
**WBT**



Sector  
**Technology**



Sub-sector  
**Semiconductors**



Stock price target  
**AUD \$3.9**



Closing price  
**AUD \$3.05**



Market cap  
**AUD \$535.93 M**



No. of shares  
**172.33 M**



Average daily trading volume  
**278,503 stocks**



Stock Performance  
(Since Jan. 2022)  
**6.27 %**

Successfully qualified ReRAM module at CEA-Leti; ReRAM selector development suitable for both embedded and discrete applications; wafers expected back from SkyWater in 2022; increased engagement with potential customers and partners; price target remains unchanged.

**Weebit Nano Ltd. is a leader in the development of next-generation memory technology. Operating since 2015, Weebit addresses the growing need for data storage and embedded non-volatile memory (NVM) technology with its new resistive random-access-memory (ReRAM) technology. In the past quarter, the company has achieved key business and technical milestones.**

### Additional significant events in recent months:

- Successfully qualified its ReRAM module manufactured by CEA-Leti, meeting industry requirements for production quality.
- ReRAM selector development deemed suitable for both embedded and discrete applications, demonstrating the ability to achieve high densities required for discrete chips using fab-friendly materials and tools.
- Wafers expected back from SkyWater in 2022 – qualification will commence immediately after.
- Increased engagement with potential customers and partners, leading fabs in different stages of engagement and evaluation.

The data storage industry is expanding exponentially, with growing demand for high-speed energy-saving memory. **The NVM market is estimated to reach around US\$88 billion by 2025, with a 10.6% CAGR.** In April 2021, US President Joe Biden announced a USD 52 billion chip investment plan; TSMC announced spending \$100 billion to expand its chip fabrication capacity over the next three years. In 2020, a study by the New South Wales’ Chief Scientist & Engineer Office flagged that the global semiconductor market for chips alone was estimated at over US\$400 billion industry, suggesting it could reach US\$1 trillion by 2030. Total sales in the global semiconductor market in 2021 grew 25% from the previous year to a total of USD 583.5 billion. Many countries – including the US, EU, China, Japan, and South Korea – have announced plans to significantly increase investment in the semiconductor industry in their respective countries (detailed in the report below). In March 2022, Fujitsu announced the largest density ReRAM-based product – 12Mb – of which evaluation samples are now available – a clear indication of the value-add of ReRAM vs. Flash, signifying that the ReRAM market is ready to take-off.

We estimate Weebit’s monthly burn rate to be approx. AUD\$1.2M. Weebit’s current cash position is strong mainly after the recent raising. This significant figure will support the company’s strategy and plans throughout 2022-2023, with no additional need to raise more capital.

Year	Revenues (000 US\$)
2022A	-
2023E	4,000
2024E	10,000

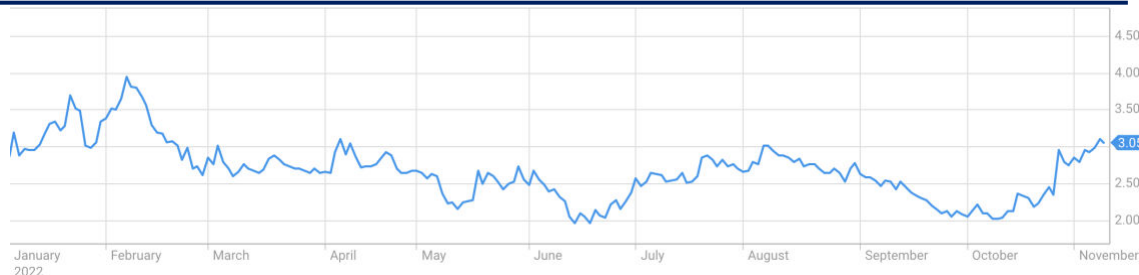

\*Conversion rates may change

<sup>1</sup> <https://www.prnewswire.com/news-releases/fujitsu-launches-12mbit-reram---largest-memory-density-in-reram-family-301502564.html>

**Significant developments since the last coverage report we published to the reporting date:**

- On October 12, the company confirmed its ReRAM selector development is suitable for both embedded and discrete applications, increasing target applications for Weebit's technology.
  - Development progress by Weebit and its R&D partner Leti has demonstrated the ability of the Weebit ReRAM selector to achieve the high densities required for discrete chips while using fab-friendly materials and standard tools.
  - This selector is also suitable for future embedded applications that will benefit from higher densities, such as edge AI and automotive.
- On October 27, Weebit announced that it successfully completed technology qualification of its ReRAM memory module produced at Leti.
  - The qualified wafer lots met JEDEC microelectronics standards for endurance, retention, and SMT reflow at industrial temperatures.
  - The qualification results from the Leti wafers enabled Weebit to engage with several Tier-1 fabs and key customers, and some of these fabs are now in different stages of evaluation.
- Throughout the previous quarter, Weebit made solid technical progress with SkyWater and, on November 8, the company announced that the first silicon wafers integrating Weebit's embedded ReRAM module have been delivered to Weebit from SkyWater's US production fab, representing a major milestone towards the commercialization of the tech at SkyWater.
  - Manufacturing of Weebit ReRAM is now proven with standard tools and a mature process flow, making it easy for customers to adopt this innovative NVM for development of their system-on-chip (SoC) designs. The silicon wafers will now be sliced into chips, packaged, and then tested and qualified.
  - Full qualification of the highly integrated demo chips in SkyWater's U.S. production fab is expected to be completed in H1 2023.
- **Marketing activity:** During this past quarter, Weebit Nano was an exhibitor and speaker at the Flash Memory Summit (FMS) 2022 – the largest global conference for the Non-Volatile Memory ecosystem. FMS provided Weebit Nano with significant exposure to potential customers and partners, and the Company is continuing to build its sales funnel ahead of volume production.
- **Summary of Q1 2023 cash flows:** The company received a French R&D tax credit of AUD 5.6M, which offset R&D expenses of AUD 218K. Payments to related parties over the quarter were AUD 194K, including fees paid to Directors and the CEO's cost of payroll.

Significant developments (cont.):

Significant Progress in Last 12 Months

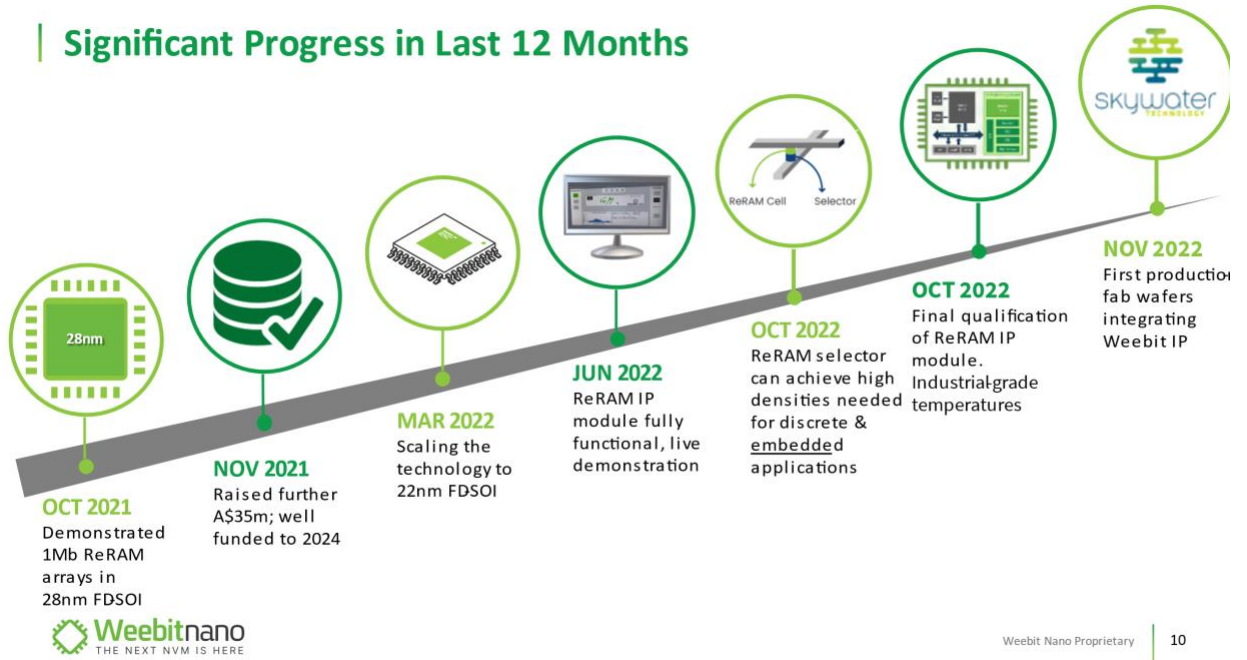

## Executive Summary

### Investment Thesis

Weebit Nano Ltd. is an Israeli company that is publicly traded on the Australian Securities Exchange (ASX: WBT). Weebit's vision is to disrupt the memory industry by replacing the reigning flash memory technology with faster, more reliable, and energy-efficient non-volatile memory (NVM) technology that is ideal for embedded applications. The company is revolutionizing NVM through fab-friendly RAM (ReRAM) technology, in collaboration with CEA-Leti, a French research institute, after receiving licensing patents from Rice University in the United States.

### The Global Emerging Memory Technologies Market

#### Size<sup>i</sup>

- The NVM market is expected to reach around US\$88 billion by 2025, with a steady growth rate of 10.6%.
- Embedded memory:
  - The AI chipset market is expected to enjoy a rapid growth rate of 31.7% from 2020 to 2025.
  - Sales of multi-core system-on-chips (SoCs) are growing at a steady rate of 17.3% per year. Around US\$45 billion is contributed by the mobile and automobile SoC market.
  - In 2019, 24 billion Internet of Things (IoT) devices were in service. According to Frost & Sullivan's analysis, there will be 58 billion IoT devices in service worldwide by 2026, with a growth rate of 15.5%.<sup>ii</sup>
- Discrete and persistent memory is expected to accelerate, with a growth rate of 11.8% from 2021 to 2025. Persistent memory is a type of non-volatile memory with performance equivalent to DRAM (dynamic RAM). Persistent Memory is introduced between DRAM, the primary storage and flash/disk, the secondary storage and acts like a high capacity cache memory capable of boosting the system performance significantly.
- According to a SEMI survey<sup>iii</sup>, European companies received only 6% of the chip purchase budgets, most of them companies selling equipment to the chip industry. In terms of market share, Europe has 10% of the global market.
  - The US has recently published its chip law, under which it will invest USD 52 billion in chip factories. China will invest about USD 150 billion over the next decade to close the technological gap between it and the rest of the world. Japan will invest about USD 8 billion. South Korea will strengthen its semiconductor industry by supporting, through tax incentives, the private

investment of its domestic companies in R&D and production, estimated at USD 450 billion by 2030, and the EU will add another USD 50 billion.

- Demand for semiconductors Increased due to increased digitization of the economy, growing demand for “smart” products, increased remote work, education and shopping and other factors. To meet this growing demand and deal with the shock in the supply chain caused by the plague, the semiconductor industry has in the short term significantly expanded shipments by increasing the utilization of existing production capacity.

### Current Challenges

- **Cost-effectiveness**

The key challenge for ReRAM companies lies in maintaining the competitive pricing of their memory modules' in comparison to other NVM technologies.

- **Optimized storage capacity and density**

Achieving storage density and capacity optimization is important before integrating into a product design. The amount of available memory in a device is critical for its use with AI and IoT applications.

- **The competitive landscape of emerging new technologies**

NVM is a highly competitive market, with new technologies such as MRAM gaining momentum.

### Weebit's Opportunities

- As a crucial element of edge AI chips, memory must have a small geometry while storing more data; ReRAM represents an ideal answer to this challenge, especially given its low-power consumption nature.
- Weebit's ReRAM offers a perfect memory alternative in SoCs as, unlike flash, it can scale to fit smaller geometries.
- IoT represents an excellent market opportunity for Weebit's ReRAM. IoT and other connected devices can be embedded with ReRAM because of its low power consumption and 10-year retention, even at high temperatures, which is a requirement for IoT field deployment.
- Various components of the wireless communication infrastructure of 5G, such as 5G chipsets, can use ReRAM as their embedded memory.
- Weebit's cost-effective back end of line (BEOL) solution, requiring only two added masks and no special fab equipment, is a good target for many cost-sensitive analog integrated circuits for smartphones, consumer electronics, industrial applications, and more.

## Weebit's Value Offering

- **Key application areas**

Weebit focuses on three key areas—embedded, discrete, and neuromorphic computing—to commercialize its ReRAM technology.

- **Technological advantages**

Weebit's ReRAM is scalable to low geometries, offers high-temperature reliability, provides manufacturing flexibility, and enables a higher number of program and erase cycles than flash and other NVM technologies. The company has successfully demonstrated working 1 megabit (Mbit) arrays at 40 nanometers. The company has also demonstrated 10-year retention at 150°C, which opens opportunities for automotive and industrial applications.

- **Cost-effective**

The production cost of Weebit's ReRAM modules is lower than that of other NVMs owing to several disruptive features of its ReRAM technology making the entire process Complementary Metal-Oxide-Semiconductor (CMOS) fab compatible; its need for only limited masks; and the minimal number of steps incorporated in its fabrication process. As a result, the ReRAM technology can be considered a cost-effective memory solution compared to other NVM technologies.

- **Strategy and business model**

The company is adopting two licensing strategies. The flexibility of these business models can be leveraged by various electronic device original equipment manufacturers (OEMs) to incorporate Weebit's ReRAM in their product designs.

## Timeline

Weebit is aggressively pursuing its' primary goals for 2022, aiming to demonstrate volume production abilities after signing its first commercial agreement. Transferring the technology into a production fab would be a significant milestone that will enable Weebit to productize the memory cell, followed by a memory module's qualification process. The company has underlined 2023 as the milestone year for its ReRAM technology to be embedded in a full-fledged product, with 2022 focusing on quality improvements and volume production.

In March 2022, the company began a collaboration with CEA-Leti to design a full IP memory module targeting an advanced 22nm FD-SOI process. The company is rapidly accelerating plans to scale Weebit ReRAM to

advanced nodes, where existing embedded flash technology is no longer a viable option. Serving applications include IoT, 5G, and AI. Weebit ReRAM + FD-SOI is ideal for low-power embedded devices.

**The memory industry is expanding exponentially, with the demand for high-speed and energy-efficient memory on the rise. While flash storage is the most prevalent technology, limitations related to factors such as scalability, endurance, and retention are opening an opportunity for emerging NVM technologies. Due to Weebit's positioning and technological solutions, we believe that the company will play a vital role in the growing NVM market, making it an excellent investment opportunity. However, because Weebit, like many technology firms, is still in the scale-up phase, with a proven technology and initiating sales efforts, its current challenge involves marketing and sales more than technology.**

## 1. Company overview

Weebit Nano Ltd. (ASX: WBT), hereafter "the Company" or "Weebit," is an Israeli company publicly traded on the Australian Securities Exchange. Weebit's vision is to disrupt the computer memory industry by replacing the reigning flash memory technology with a faster, more reliable, and energy-efficient non-volatile memory (NVM) technology ideal for embedded applications. The Company is revolutionizing NVM through fab-friendly RAM (ReRAM) technology, in collaboration with CEA-Leti, a French research institute specializing in electronics and information technologies, after licensing patents from US-based Rice University. The company operates out of its HQ in Hod Hasharon, Israel.

Weebit focuses on three key application areas to commercialize its ReRAM technology, with embedded applications being the prime focus in the near term. The company is developing a memory module that can be embedded within a system on chip (SoC) or a sensor.

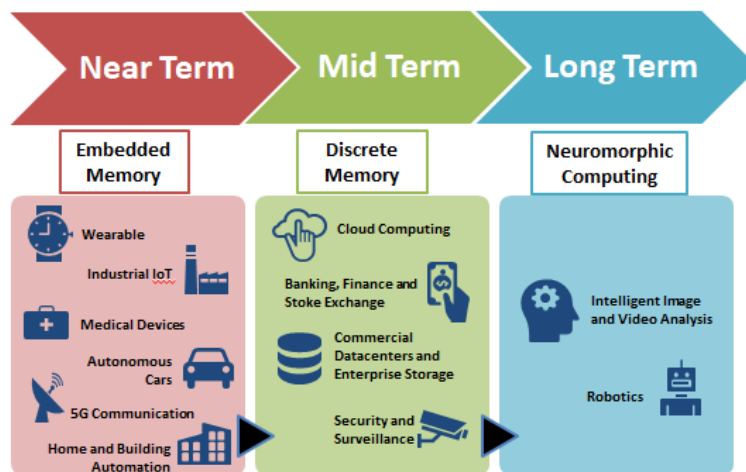

**Fig 1: Application Landscape of ReRAM Technology**

Flash memory has dominated the NVM industry because of its ease of use in various applications, ranging from smartphones to data centers. As a result, any new NVM technology faces stiff competition from flash memory. To prevail in the NVM storage's competitive landscape, Weebit Nano immediately realized that the fastest path to generating revenue is by investing in embedded applications. Initial adoption of ReRAM technology will be across embedded applications such as wearables, medical implants, and home and industrial automation. The company also realized the potential of ReRAM in emerging applications, such as 5G, AI, Big Data, and IoT, where flash storage cannot be deployed because of its scalability and power efficiency limitations.

Moreover, Weebit's ReRAM memory modules could make steady inroads into flash dominated discrete memory sector. The NOR flash memory cannot be stacked in three dimensions unlike NAND flash or ReRAM paving way



for an opportunity for ReRAM to penetrate discrete memory sector. The ReRAM modules can be stacked in enterprise storage, cloud storage, and other commercial data centers used by hospitals, governmental bodies, and education institutes as data repositories. In the future, ReRAM can be used for brain-computer interface devices and advanced AI, making it a promising memory technology for neuromorphic computing.

Weebit realigned its vision by adjusting its offering based on the ever-changing memory industry's needs while strengthening its core technological offering, ReRAM, through constant research and indigenization.

## Products and Technology

One of the key limitations of flash storage and other NVM technologies is their inability to scale below 28 nanometers (nm). In contrast, ReRAM has no problem going beyond 20 nm. With the future of semiconductor chipsets moving toward miniaturization, ReRAM's ability to fit within the smallest geometry could be disruptive. Moreover, while 3D NAND technology has provided a great reprieve for secondary storage devices, such as solid-state drives (SSDs), it is not feasible for embedded storage, thus making ReRAM an interesting proposition for applications relying on embedded NVM.

Unlike the traditional memory, where the data is stored in the form of an electrical charge, ReRAM technology leverages special resistive material sandwiched between two electrodes whose resistance is varied to record the binary data (0s and 1s) by applying an external voltage.

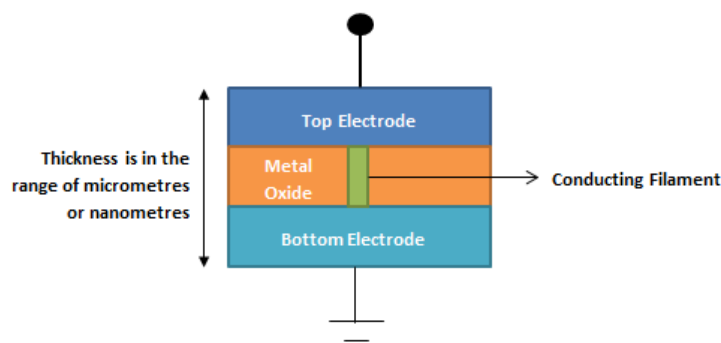

**Fig 3: Schematic Representation of ReRAM cell**

Weebit's disruptive ReRAM cell is comprised of a thin metal oxide switching layer between two electrodes. In an initial, one-time, forming step, a positive voltage is applied to an electrode, which reversibly changes the resistance of the oxide layer to a low resistance state (LRS). During this process, a conduction filament of oxygen vacancies is formed through the oxygen ions. This increases the flow of current in one direction and decreases it in the other direction. The level remains intact – maintaining the data – until the cell is purposefully reset by

applying a negative voltage to break the filament, thus migrating to a High Resistive State (HRS). Applying positive and negative voltages can cause the cell to switch from one state to the other, encoding the binary information by creating either a 1 (LRS) or a 0 (HRS) data store in the memory cell.

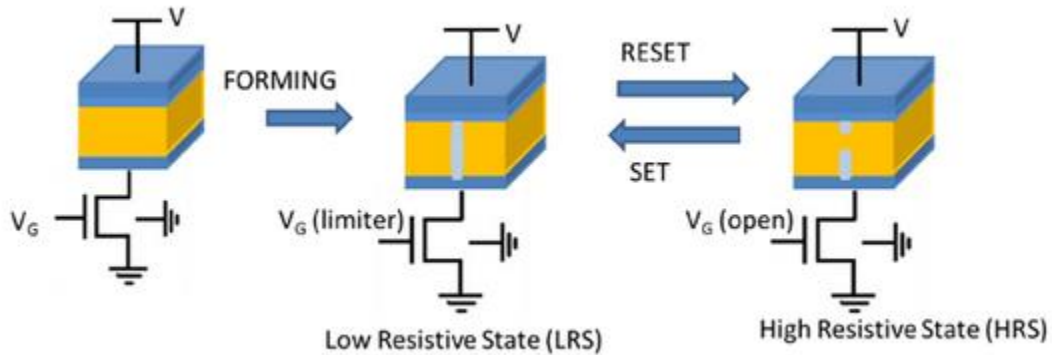

**Fig 4: Functional Diagram of Weebit's ReRAM Cell**

Weebit uses the standard tools and technology available in the semiconductor industry. To maintain this standardization, the company ensures that the devices and machines used in the cleanroom of Leti's in-house fabrication facility are common in any global fabrication facility. As a result, Weebit has successfully produced its memory cells on different process nodes associated with various fabrication facilities, thus providing an impetus to the company's goal of establishing a fabrication-friendly technology. Another key aspect of Weebit's ReRAM technology is its ease of integration into existing CMOS-fabricating facilities, which will significantly decrease the time to market and cost of production.

Weebit has completed the stabilization process, which is an essential precursor for production. The uniformity through the cell and the die was validated as no changes were observed in the wafer characteristics. Moreover, the same level of endurance was observed across multiple wafers.

#### **Additional Benefits of Weebit's ReRAM Technology include:**

- **High Endurance:** The memory cell exhibits a very high endurance of one million cycles, unlike flash storage, which has a maximum endurance of few thousand cycles.
- **High Retention:** The memory cell can withstand high temperatures of up to 150 Celsius degrees, with data retention of 10 years.

- **Short Read/Write Time:** The time taken by the cell to read/write data is in the order of tens of nanoseconds, unlike flash, which offers a read/write time of few microseconds, thereby making ReRAM a high-speed memory.
- **Low Power Consumption:** The memory cell consumes around 0.1 Joule for writing one bit of data.
- **Scalability:** The ReRAM architecture could possibly be shrunk (full shrinking potential is still under research) to few nanometers of 20, 16, or 5, unlike flash, which doesn't shrink below 40 nm.
- **Futuristic Memory Technology:** The ReRAM architecture resembles biological synapses found in the human brain, making it an ideal starting point for the design of brain-inspired AI systems.

## 2. Emerging Memory Technologies Market Overview

The data storage industry is expanding exponentially, with the demand for high-speed and energy-efficient memory on the rise. Because of the revival of flash storage, major data storage participants, such as Samsung, Intel, Micron, Western Digital (WD), Toshiba, and SanDisk, are developing their own proprietary 3D NAND flash technology. As a result, the NVM industry has facilitated the growth of small and medium data storage companies focusing on emerging NVM technologies, such as MRAM, ReRAM, and FRAM. The semiconductor memory industry is pursuing research and development in the emerging NVM technologies to integrate notable features of conventional memory storage such as the high switching speed of static RAM, storage density equivalent to dynamic RAM, and non-volatile functionality of flash memory. The successful culmination of all the features mentioned above will result in an attractive NVM solution for computation-intensive workloads.

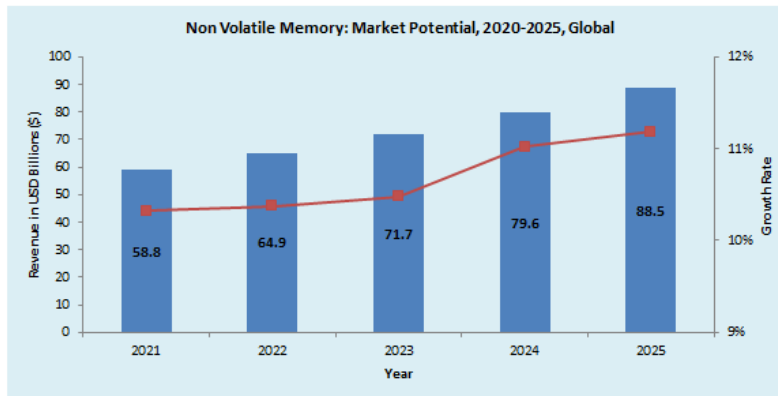

**Fig 6: Market Potential of NVM**

Source: Frost & Sullivan

NVM market is expected to reach around \$88 billion by 2025, with a steady growth rate of 10.6%. The NVM market will be dominated by flash memory with new flash variants such as 3D NAND, NVMe (non-volatile memory express). Still, its limitations, such as scalability, endurance, and retention, will create a platform for emerging NVM technologies and companies like Weebit to play a vital role in the embedded device sector.

As per the SIA data (Semiconductor Industry Association), the global semiconductor industry reported sales of \$414 billion in 2019, making it one of the highly lucrative markets at present. This will give an ample commercial drive for the growth of ReRAM and Weebit as its technology can be embedded in almost all of the semiconductor products ranging from logic, analog, MPUs (microprocessor units), MCUs (microcontroller units), sensors, and signal processors. Below is a split of various semiconductor products and their sales recorded, which will give a

clear overview of the potential technology to disrupt the semiconductor industry while defining the market opportunity for Weebit.

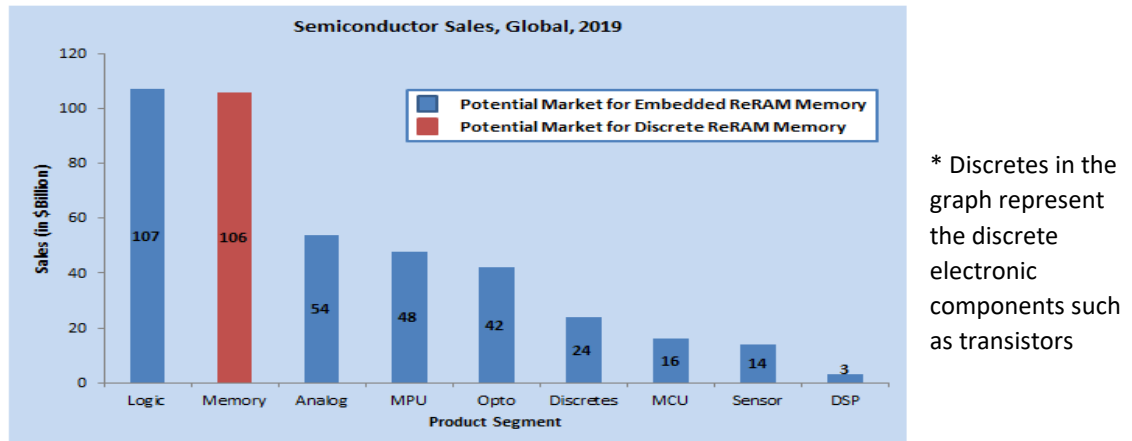

**Fig 7: Global Semiconductor Sales for 2019**

Source: SIA

Global computer chip sales in 2021 rose 25% from 2020 to a record USD 583.5 billion<sup>1</sup>, due to a combined factor of the global semiconductor shortage and growing demand. Industry executives expect that total to double in less than a decade to more than USD 1 trillion.

## Core Focus Areas of Weebit Nano Ltd

### Embedded Memory

Today, AI has penetrated every mainstream industry, such as agriculture, automotive, finance, manufacturing, education, entertainment, and healthcare, thereby propelling intelligent chipsets' innovations. In particular, edge AI's demand is gaining momentum due to the special feature of edge intelligence. The data is processed locally on the device instead of the conventional method of cloud-based data processing. As a critical part of edge AI chips, memory needs to have a small geometry and store more data, which is where ReRAM can be an ideal solution. As per Frost & Sullivan's analysis, the AI Chipset market will be accelerating at a growth rate of 31.7% from 2020 to 2025. The growth rate will pick up pace by 2022 due to advancements in various technologies such as lithography, memory storage, display and software algorithms that form the core of the AI ecosystem. With the commercialized ReRAM modules of Weebit slated to be released by 2022, the company will be looking forward to cash-in on the steep growth of the edge AI chips market as the ReRAM can be an ideal embedded memory for various edge AI and smart devices.

<sup>1</sup> <https://www.wsj.com/articles/for-chip-industry-global-supply-crunch-pushes-next-target-to-1-trillion-11643544005>

System-on-chips (SoCs) are becoming an integral part of the system design of major electronic devices used across various industries, such as consumer electronics, automotive, healthcare, and energy. The next generation of multi-core SoCs will be embedded with features, such as AI, which will bring in automation capabilities to the process chain and significantly impact the manufacturing and processing industry. Multi-core SoCs bring the capabilities of multiple processing instances interfaced with other features, such as signal antennas, sensor interfaces, which are vital to embedded systems. With the devices becoming feature-rich and shrinking in size with each passing day, multi-core SoCs will play a pivotal role in realizing this transition. Frost & Sullivan analysis indicates that multi-core SoCs are growing at a steady rate of 17.3% due to technological advancements in circuit miniaturization and the introduction of multiple-core processors in the integrated circuits. Around US\$45 billion is contributed by the mobile and automobile SoC market. Embedded memory would be a vital entity of SoCs as it will have to process multiple actions simultaneously. ReRAM can be a perfect memory alternative in SoCs as it can shrink to smaller geometries, unlike flash.

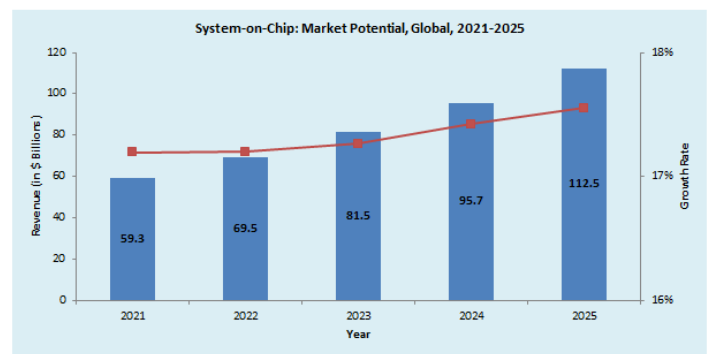

Source: Frost & Sullivan

IoT is a critical component of digital transformation observed across various industries. Banking upon its core concepts that include real-time connectivity and advanced data analytics, IoT is making significant inroads across different application areas ranging from healthcare to manufacturing and retail. Frost & Sullivan's analysis indicates that 24 billion IoT devices were in service in 2019 and predicts there will be 58 billion IoT devices in service worldwide by 2026, with a growth rate of 15.5%. The key areas where IoT is being leveraged include asset monitoring and tracking, connected cars, automotive infotainment, smart grid, smart energy meters, smart home appliances, building automation, security and surveillance, digital signage, ATMs, retail outlets, industrial automation, and medical devices. In particular, the connected devices sector has undergone a rapid transition owing to the constant upgrades and innovations observed in the IoT domain. Electronic gadgets are becoming intelligent day by day as they are now capable of automating various sophisticated tasks through wireless connectivity with Bluetooth and Wi-Fi. The intelligence of the electronic devices can be accredited to

the growth of SoCs and NVM. As devices are shrinking, IoT poses a great market opportunity for Weebit's ReRAM as IoT and other connected devices, such as wearables, drones, robots and Bluetooth speakers that can be embedded with ReRAM because of its low power consumption and small geometry.

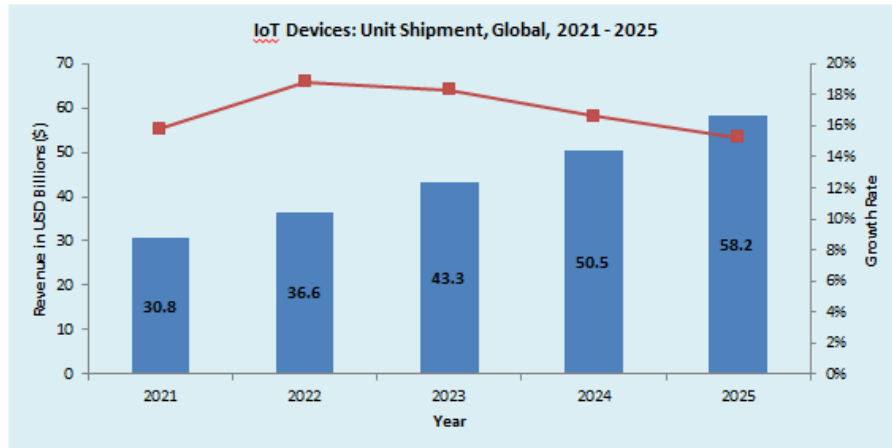

**Fig 8: Unit Shipment Forecast of IoT Devices**

Source: Frost & Sullivan

Finally, the wireless communication market inclusive of 5G communication is on the verge of commercialization and pose a potential opportunity for Weebit's ReRAM technology. Wireless technology is used to establish connectivity between different communication networks located in and around enterprises, public places, and residential premises. 5G will be a key enabler for the digital transformation in the near future. It brings in faster speed, high bandwidth, and low latency, which will spur innovations and the deployment of billions of connected devices globally. The key application segments for this market are automotive, consumer electronics, healthcare, public safety, wearable devices, energy, etc. Various components of the wireless communication infrastructure of 5G, such as 5G chipsets, can use ReRAM as its embedded memory.

### Discrete and Persistent Memory

In the discrete memory sector, Flash memory (in particular, NAND flash) has been enjoying a global supremacy in terms of market share, which is further boosted by developing 3D architecture of NAND Flash. But the major area wherein Flash usage has seen a rapid growth is the cloud storage and data centers. As massive data processing using AI and machine learning increases, the storage demand has to be met accordingly. Weebit's ReRAM offers great benefits for endurance and retention in comparison to Flash memory. We expect the company to target the NOR Flash and EEPROM replacement by 2024 -2025, enabling Weebit to enter the discrete memory market comprehensively. Moreover, the ability to scale in three dimensions will enable Weebit to develop 3D ReRAM in the future, thereby aiming to acquire a significant NAND flash market share.

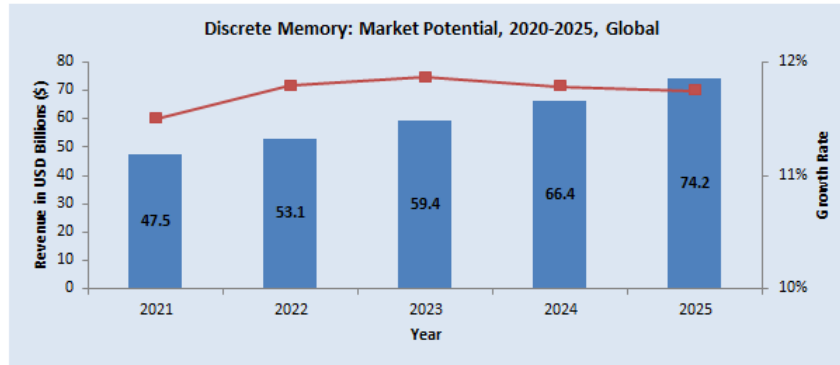
**Fig 9: Market Potential of Discrete Memory***Source: Frost & Sullivan*

Another key memory segment targeted by Weebit is the standalone memory chips that offer better endurance, speed, and retention in comparison to flash memory. One of the major limitations found in today's data storage industry is the void found between DRAM (dynamic RAM), the primary memory which is very fast and volatile and the secondary memory, which is slow and non-volatile, hampering the overall processing capabilities of systems in data centers and cloud computing networks. An emerging memory technology called persistent memory, which is non-volatile, is gaining momentum due to its ability to accelerate secondary storage. Weebit's ReRAM offers high read/write speed and low power consumption, making it a perfect solution for persistent memory. In collaboration with CEA-Leti, the company has launched a three-stage program to develop the ReRAM based discrete memory modules by 2024.



## Disclaimers, disclosures, and insights for more responsible investment decisions

**Definitions:** "Frost & Sullivan" – A company registered in California, USA with branches and subsidiaries in other regions, including in Israel, and including any other relevant Frost & Sullivan entities, such as Frost & Sullivan Research & Consulting Ltd. ("FSRC"), a wholly owned subsidiary of Frost & Sullivan that is registered in Israel – as applicable. "The Company" or "Participant" – The company that is analyzed in the report; "Report", "Research Note" or "Analysis" – The content, or any part thereof where applicable, contained in a document such as a Research Note and/or any other previous or later document authored by "Frost & Sullivan", regardless if it has been authored in the frame of the "Analysis Program", if included in the database at [www.frost.com](http://www.frost.com) and regardless of the Analysis format-online, a digital file or hard copy; "Invest", "Investment" or "Investment decision" – Any decision and/or a recommendation to Buy, Hold or Sell any security of The Company. The purpose of the Report is to enable a more informed investment decision. Yet, nothing in a Report shall constitute a recommendation or solicitation to make any Investment Decision, so Frost & Sullivan takes no responsibility and shall not be deemed responsible for any specific decision, including an Investment Decision, and will not be liable for any actual, consequential, or punitive damages directly or indirectly related to The Report. Without derogating from the generality of the above, you shall consider the following clarifications, disclosure recommendations, and disclaimers. The Report does not include any personal or personalized advice as it cannot consider the particular investment criteria, needs, preferences, priorities, limitations, financial situation, risk aversion, and any other particular circumstances and factors that shall impact an investment decision. Nevertheless, according to the Israeli law, this report can serve as a *raison d'être* off which an individual/entity may make an investment decision.

Frost & Sullivan makes no warranty nor representation, expressed or implied, as to the completeness and accuracy of the Report at the time of any investment decision, and no liability shall attach thereto, considering the following among other reasons: The Report may not include the most updated and relevant information from all relevant sources, including later Reports, if any, at the time of the investment decision, so any investment decision shall consider these; The Analysis considers data, information and assessments provided by the company and from sources that were published by third parties (however, even reliable sources contain unknown errors from time to time); the methodology focused on major known products, activities and target markets of the Company that may have a significant impact on its performance as per our discretion, but it may ignore other elements; the Company was not allowed to share any insider information; any investment decision must be based on a clear understanding of the technologies, products, business environments, and any other drivers and restraints of the company's performance, regardless if such information is mentioned in the Report or not; an investment decision shall consider any relevant updated information, such as the company's website and reports on Magna; information and assessments contained in the Report are obtained from sources believed by us to be reliable (however, any source may contain unknown errors. All expressions of opinions, forecasts or estimates reflect the judgment at the time of writing, based on the Company's latest financial report, and some additional information (they are subject to change without any notice). You shall consider the entire analysis contained in the Reports. No specific part of a Report, including any summary that is provided for convenience only, shall serve per se as a basis for any investment decision. In case you perceive a contradiction between any parts of the Report, you shall avoid any investment decision before such contradiction is resolved. Frost and Sullivan only produces research that falls under the non-monetary minor benefit group in MiFID II. As we do not seek payment from the asset management community and do not have any execution function, you are able to continue receiving our research under the new MiFID II regime. This applies to all forms of transmission, including email, website and financial platforms such as Bloomberg and Thomson.

**Risks, valuation, and projections:** Any stock price or equity value referred to in The Report may fluctuate. Past performance is not indicative of future performance, future returns are not guaranteed, and a loss of original capital may occur. Nothing contained in the Report is or should be relied on as, a promise or representation as to the future. The projected financial information is prepared expressly for use herein and is based upon the stated assumptions and Frost & Sullivan's analysis of information available at the time that this Report was prepared. There is no representation, warranty, or other assurance that any of the projections will be realized. The Report contains forward-looking statements, such as "anticipate", "continue", "estimate", "expect", "may", "will", "project", "should", "believe" and similar expressions. Undue reliance should not be placed on the forward-looking statements because there is no assurance that they will prove to be correct. Since forward-looking statements address future events and conditions, they involve inherent risks and uncertainties. Forward-looking information or statements contain information that is based on assumptions, forecasts of future results, estimates of amounts not yet determinable, and therefore involve known and unknown risks, uncertainties and other factors which may cause the actual results to be materially different from current projections. Macro level factors that are not directly analyzed in the Report, such as interest rates and exchange rates, any events related to the ecosystem, clients, suppliers, competitors, regulators, and others may fluctuate at any time. An investment decision must consider the Risks described in the Report and any other relevant Reports, if any, including the latest financial reports of the company. R&D activities shall be considered as high risk, even if such risks are not specifically discussed in the Report. Any investment decision shall consider the impact of negative and even worst case scenarios. Any relevant forward-looking statements as defined in Section 27A of the Securities Act of 1933 and Section 21E the Securities Exchange Act of 1934 (as amended) are made pursuant to the safe harbor provisions of the Private Securities Litigation Reform Act of 1995.

The Report shall include a description of the Participant and its business activities, which shall inter alia relate to matters such as: shareholders; management; products; relevant intellectual property; the business environment in which the Participant operates; the Participant's standing in such an environment including current and forecasted trends; a description of past and current financial positions of the Participant; and a forecast regarding future developments and any other matter which in the professional view of Frost & Sullivan (as defined below) should be addressed in a research Report (of the nature published) and which may affect the decision of a reasonable investor contemplating an investment in the Participant's securities. An equity research abstract shall accompany each Equity Research Report, describing the main points addressed. A thorough analysis and discussion will be included in Reports where the investment case has materially changed. The named lead analyst and analysts responsible for this Report certify that the views expressed in the Report accurately reflect their personal views about the Company and its securities and that no part of their compensation was, is, or will be directly or indirectly related to the specific recommendation or view contained in the Report. Neither said analysts nor Frost & Sullivan trade or directly own any securities in the company. The lead analyst has a limited investment advisor license for analysis only.

This research paper is not intended for, and should not be used by, investors in Australia. Frost & Sullivan does not hold an Australian financial services licence and is not regulated by the Australian Securities and Investments Commission in connection with the preparation of this research paper or its publication. This research paper is for information purposes only and should not be treated as an opinion, proposal, recommendation or advice for the investment in, holding or disposal of the securities described in it. It has been prepared without taking into account any client's individual circumstances and investors should therefore consider whether an investment in the securities described in this research paper (Securities) is appropriate for them having regard to their own circumstances. Investors should seek their own independent professional advice from an appropriately licensed person before making any such decision. Any advice contained within this research paper is only intended for wholesale investors. Recipients of this research paper, including the issuer of the Securities, are strictly prohibited from permitting retail investors to view, obtain or download a copy of the research paper or placing it on a website or other forum where a retail investor may obtain access to it.

© 2021 All rights reserved to Frost & Sullivan and Frost & Sullivan Research & Consulting Ltd. Any content, including any documents, may not be published, lent, reproduced, quoted or resold without the written permission of the companies.

## Endnotes

---

<sup>i</sup> Frost & Sullivan annual reports: Top 50 Emerging Technologies: Spawning Growth Opportunities of Strategic Imperative, 2018, 2019, 2020

<sup>ii</sup> Frost & Sullivan annual reports: Total Internet of Things (IoT) Device Forecast, 2017-2025

<sup>iii</sup> [Chiportal: מדינת ישקיעו כ-700 מיליארד דולר בעשור הקרוב בתעשיית השבבים](#)